



# Hydraulic Workshop Tester - CHES

- 1 **SAFETY** : Avoids the use of a tractor to test machinery.
- 2 **ENVIRONMENT** : No more noise & fumes in the workshop
- 3 **VERSATILE** : Designed to perform hydraulic and electrical tests

## No more noisy tractors in the workshop !

### APPLICATIONS

- Replaces the tractor for the testing of coupled equipment in the workshop
- Safety of use that a tractor does not provide (emergency stop, thermocontact)
- PTO safety (option): control of rotation speed from 0 to 1000 rpm + retractable stabiliser
- Electrically operated (no exhaust gases in the workshop)
- Can be moved by hand
- Easy to read flow and pressure measurements
- Lower investment
- Less energy consumed
- Less maintenance
- Time saving (allows autonomous work)

Video

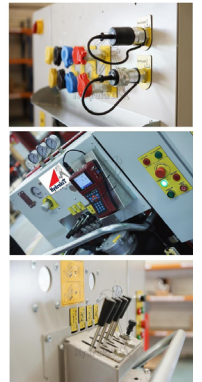

### GENERAL DIMENSIONS

- Maximum width : 1328 mm
- Maximum length : 937 mm
- Height : 1488 mm
- Weight without oil : depending on equipment up to 500 kg
- Weight with oil : + 60 kg to 80 kg depending on the tank
- Tank volume : 80L or 100L
- Cabinet dimensions : 500 x 700 x 260 mm

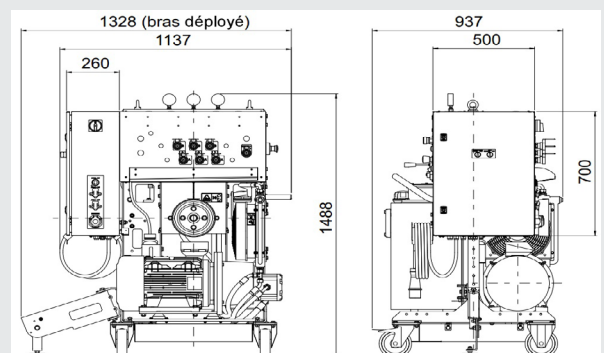

# FEATURES

## Hydraulics :

- Oil flow rate : up to 45 L/min
- Oil pressure : up to 200 bar
- Hydraulic pump : gear unit 2-3 up to 33 cm<sup>3</sup>/rev
- Flow control: 3-way single-turn adjustment 0-50 L/min
- Valve: 45 L/min with manual controls up to 5 functions
- Couplings: ISO-A push-pull valves with dust caps
- Pressure gauges : 0-250 bar on each function
- 80 or 100 Litres tank
- Filtration: 25 µm semi-submerged return filter
- Maximum oil temperature: 80 °C

## Electrical :

- Motor type: 3-phase induction
- Motor power: 3-4-5.5-7.5-11-15-22kW
- Motor speed 1500 rpm
- Motor current: from 6.2 to 28.1 A (400V)
- Complete electrical cabinet (ARU, elec ON/OFF control, lighting test controls)
- Auxiliary power supplies 12 VDC - 10 A (1 x 7-pin trailer socket, 2 x 3-pin sockets, 1 x 2-pin socket)
- High temperature protection
- Automatic phase correction
- Fault indicator lights
- Direct or soft start motor

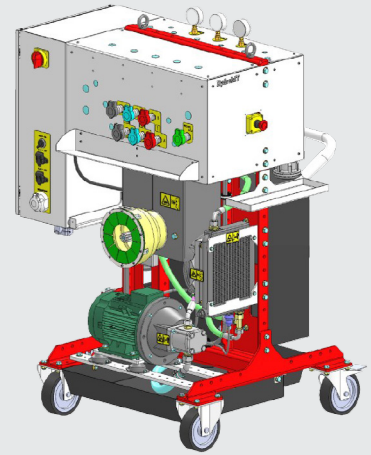

## Option :

- PVG 16/32, CETOP 3 electrically controlled
- Variable displacement pump
- Radio-controlled hydraulic functions
- Power take-offs (PTO) 1" 3/8 6 splines + revolution counter
- Oil cooler
- Hydraulic tester (flow, pressure, temperature info)
- Hour meter

# DESCRIPTION

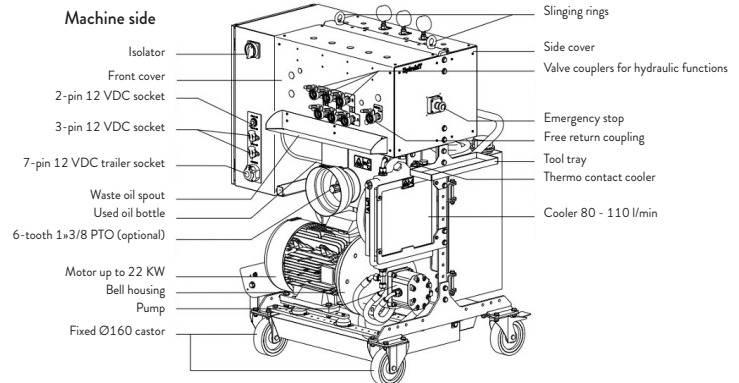
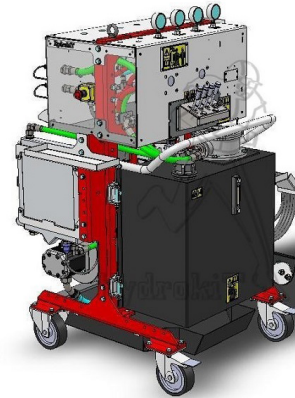
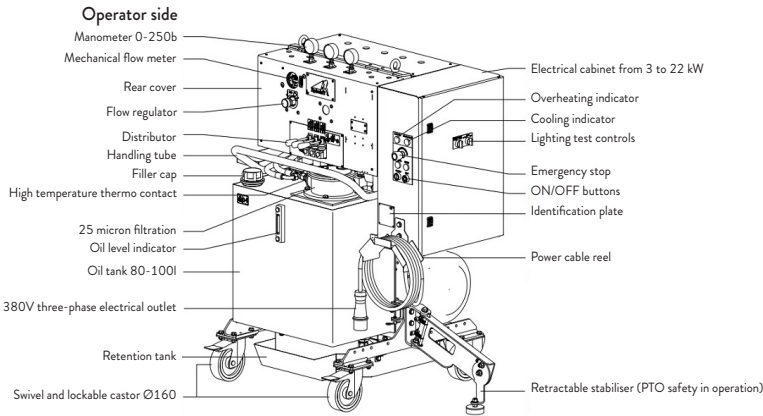

+44 (0)1728 684800  
 info.uk@hydrokit.com  
 www.hydrokit.com

Units 12 & 13, Yew Tree Courtyard, Earl Soham  
 WOODBRIDGE - IP13 7SG Suffolk-UK